



## M8 – Extension Cables

**Extremely robust extension cables with  
the best possible tightness and gold contacts**



**INDUSTRIAL  
COMPONENTS**

## M8 – Extension Cables

Our M8 extension cables are the perfect link in your automation applications. The PUR cables used with high alternating bending strength, robust housing materials, gold-plated contacts and protection class IP67, ensure a long lifetime in harsh environments.

### Properties:

- Shock and vibration resistant due to integrated lock
- 100 % tested
- Extremely robust design for the harshest environments
- Connector directly overmoulded for optimum tightness
- Gold-plated contacts for best possible conductivity
- RoHS compliant
- Customised designs upon request (e.g. connector, cable lengths etc.)

### Technical data:

Operating voltage	maximum 60 V
Connection interface	M8x1 connector on M8x1 socket, straight
Operating current per contact	maximum 4 A
Protection class	IP67
Operating temperature	-30 °C to 85 °C
Wire cross-section	3 x 0.25 mm <sup>2</sup>
Cable lengths	0.3 m / 0.6 m / 1 m / 1.5 m / 2 m / 3.5 m / 5 m

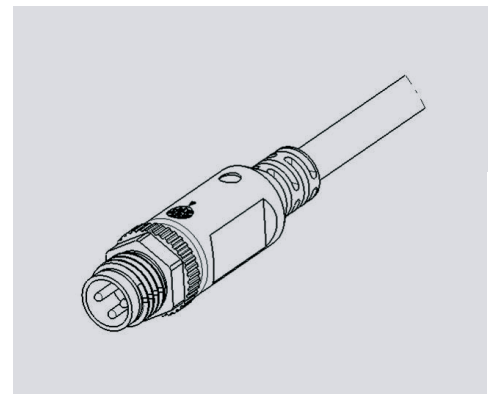

Pin side view

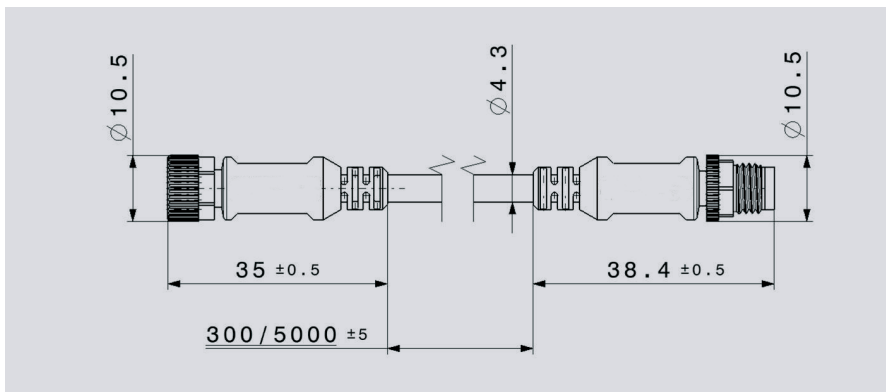

Dimensions

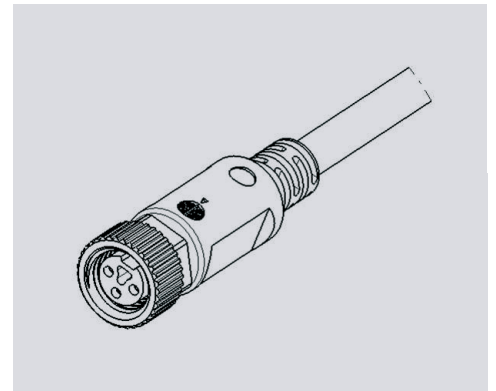

Socket side view

Hirschmann Industrial Components  
Oberer Paspelsweg 6-8  
6830 Rankweil, Austria  
Markus Kreuter  
M +43 (0)664 3382006  
markus.kreuter@hirschmann-automotive.com  
www.hirschmann-automotive.com